



Total Kitchen Solution

OUR MOTTO : We strive for Excellence in Service

OUR PRINCIPALES Quality Assurance • After Sales Service • Client Satisfaction • Commercial Growth

Walkin Cold Room

COOLING SYSTEM - EUROPEAN DESIGN AND TECHNOLOGY

The cooler is designed to respond to the Changing demand by offering innovated and Highly technical solutions based on best engineering techniques and selection of components and materials.

Ideal for stocking food products with a controlled temperate between +10 Deg C and -25 Deg C

CONSTRUCTION

Modular panels are connected with cam lock - all walls, ceilings and floor Panel

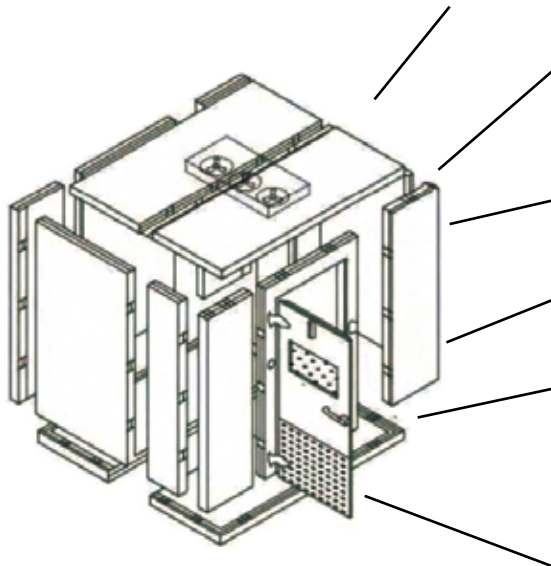

INSULATION

4" extruded polystyrene coolers and freezer P.O Density is 40 Kg/m³ to 44 Kg/m³

SKIN

20 swg Stainless Steel or 22 swg Galvanized, Painted Steel.

FLOORS

14 swg Stainless Steel or GI.

DOORS, WITH VIEW PORT GLASS

Self Closing, Flush mount with magnetic gasket, Chrome latches and hinges, safety release handle, Automatic Self Closer, Vapour proof light and thermometer, Strip curtains, Kick Plates on both sides of the Door with alarming System.

REFRIGERATION

Available both in Water and Air Cooled models.

POLY URETHANE INSULATION

Superior Insulating properties of our PUF panels come with a wide Verity of thickness 25'; 3", 4"S" & 6" and significantly help in reducing operating cost. These PUF panels come with tongue and groove arrangement with cam locks. Foamed in place through high precision CNC machines come in Pre- painted sheet s as well as food Grade SS.

PANEL

Pre Fabricated, Insulated Metal laminated panels

Insulation of Rigid Poly Urethanes Foam (RPUF)

Metal Laminated Pre-Painted Galvanized Steel (PPGS) or Stainless Steel (SS)

Panel Width of 1200mm

Joinery is achieved through Cam locks and finished with Silicon Sealant



Walk in Refrigerator / Freezer (Single Room) Walk in Refrigerator / Freezer (Double Room)



Adjustable Shelving



Installation of Walk in Cooler



Bakery Equipment



1Deck/ 2 Tray Baking Oven – Gas

Dimension(mm) : 1340 x 880 x 650
Tray Size : 400 x 600mm
Temp : 20 ~ 350°C
Power : 0.1 kw, 220V



1Deck/2 Tray Baking Oven - Electric

Dimension(mm) : 1260 x 850 x 570
Tray Size : 400 x 600mm
Temp : 20 ~ 300°C
Power : 6.3 kw, 220V



Electric Baking Oven

Dimension(mm) : 865 x 715 x 450
Power : 3.0 kw, 220V



Electric Convection Oven

Dimension(mm) : 595 x 600 x 580
Baking Pan (mm) : 435 x 315 x 4 Pcs.
Power : 2.6 kw, 220V



Bread Slicer

Dimension(mm) : 650 x 660 x 760
Slice Qty : 31 Nos.
Thickness of Slice : 12mm
Power : 0.25 kw, 220V



Dough Sheeter – Floor Type

Dimension(mm) : 2700 x 900 x 1100
Dough Capacity : 5 Kgs/Charge
Power : 0.55 kw, 220V
Also available in Table Top Model



Planetary Mixer

Capacity : 20 Ltrs.
Raw Flour : 6 Kgs.
Power : 0.75 kw, 220V
Also available in 5, 10 , 30 , 40 Ltrs.



Spiral Mixer (Double Speed)

Capacity : 20 Ltrs.
Raw Flour : 6 Kgs.
Power : 1.1 kw, 220V
Also available in 10 , 30 , 40, 50 Ltrs.

Refrigeration Equipment – Ventilated Cooling



2 Door Vertical Chiller / Freezer
Capacity : 600 Ltrs.
Dimension(mm) : 680 x 810 x 2010
Temp : -2oC ~ 8oC / -22oC ~ -18oC
Power : 0.21kw, 220V / 0.47kw, 220V



2 Glass Door Chiller
Capacity : 282 Ltrs.
Dimension(mm) : 1360 x 700 x 850
Temp : -2oC ~ +8oC
Power : 0.22kw, 220V



4 Door Vertical Chiller / Freezer
Capacity : 1200 Ltrs.
Dimension(mm) : 1340 x 810 x 2010
Temp : +2oC ~ +8oC / -22oC ~ -18oC
Power : 0.41kw, 220V / 0.73kw, 220V



3 Glass Door Work Top Chiller
Capacity : 417 Ltrs.
Dimension(mm) : 1795 x 700 x 850
Temp : -2oC ~ +8oC
Power : 0.23kw, 220V



2 Door Work Top Chiller/ Freezer
Capacity : 282 Ltrs.
Dimension(mm) : 1360 x 700 x 850
Temp : -2oC ~ +8oC / -22oC ~ -18oC
Power : 0.22kw, 220V / 0.52kw, 220V



2 Door Salad Counter
Capacity : 5 x 1/6 GN Pan
Dimension(mm) : 900 x 700 x 970
Temp : -2oC ~ +8oC
Power : 0.25kw, 220V



3 Door Work Top Chiller / Freezer
Capacity : 417 Ltrs.
Dimension(mm) : 1795 x 700 x 850
Temp : -2oC ~ +8oC / -22oC ~ -18oC
Power : 0.23kw, 220V / 0.56kw, 220V



3 Door Salad Counter
Capacity : 8 x 1/6 GN Pan
Dimension(mm) : 1365 x 700 x 970
Temp : -2oC ~ +8oC
Power : 0.30kw, 220V

Refrigeration Equipment – Static Cooling



2 Door Vertical Chiller / Freezer
Capacity : 369 Ltrs.
Dimension(mm) : 620 x 692 x 1887
Temp : 0oC ~ +10oC / -18oC ~ -15oC
Power : 0.16kw, 220V / 0.17kw, 220V



4 Door Vertical Chiller / Freezer
Capacity : 820 Ltrs.
Dimension(mm) : 1220 x 692 x 1887
Temp : 0oC ~ +10oC / -18oC ~ -15oC
Power : 0.29kw, 220V / 0.30kw, 220V



2 Door Work Top Chiller/ Freezer
Capacity : 271 Ltrs.
Dimension(mm) : 1200 x 700 x 800
Temp : 0oC ~ +10oC / -18oC ~ -12oC
Power : 0.16kw, 220V / 0.35kw, 220V



3 Door Work Top Chiller/ Freezer
Capacity : 492 Ltrs.
Dimension(mm) : 1800 x 700 x 800
Temp : 0oC ~ +10oC / -18oC ~ -12oC
Power : 0.16kw, 220V / 0.35kw, 220V



2 Door Back Bar Chiller
Capacity : 224 Ltrs.
Dimension(mm) : 920 x 515 x 905
Temp : +2oC ~ +8oC
Power : 0.16kw, 220V



3 Door Back Bar Chiller
Capacity : 338 Ltrs.
Dimension(mm) : 1350 x 515 x 905
Temp : +2oC ~ +8oC
Power : 0.25kw, 220V



2 Door Cold Bain Marie
Capacity : 6 x ½ GN Pan
Dimension(mm) : 1200 x 700 x 800
Temp : -5oC ~ +5oC
Power : 0.2kw, 220v
Also available in 3 Door



Ice Cube Machine
Dimension(mm) : 550 x 656 x 880
Capacity : 45 Kgs/ Days
Power : 0.36kw, 220V
Also available in 60 kgs



Mini Ice Cube Machine
Dimension(mm) : 360 x 440 x 450
Capacity : 15 Kgs/Days
Power : 0.21kw, 220V

Snack Equipment



Single Deck Sandwich Griller
Dimension(mm): 305 x 400 x 210
Power: 1.8 kw, 220V



Double Deck Sandwich Griller
Dimension(mm) : 580 x 410 x 210
Power : 3.6 KW, 220V



6 Slot Toaster
Dimension(mm) : 460 x 210 x 225
Power : 3.3 kw, 220V



Deep Fat Fryer Single Tank (10L)
Dimension(mm) : 370 x 440 x 340
Power : 3.2 kw, 220V
Also available in 6 & 17 Ltrs.



Deep Fat Fryer Double Tank (10L + 10L)
Dimension(mm) : 725 x 440 x 345
Power : 3.2 + 3.2 kw, 220V
Also available in 6 & 17 Ltrs.



Double Deck Pizza Oven
Dimension(mm) : 560 x 570 x 440
Inner Chamber (mm) : 400 x 400 x 135
Power : 3.0 kw, 220V



Griddle Plate – Elec. (½ smooth+ ½ Grove)
Dimension (mm) : 600 x 520 x 310
Power : 5 kw, 220V
Also available in Flat Range



Griddle Plate - Gas (½ smooth+ ½ Grove)
Dimension (mm) : 600 x 590 x 500
Also available in Flat Range



Food Warming Lamp
Dia : 290 mm
Power : 0.25 kw, 220V



Single Group Coffee Machine
Size(mm) : 430 x 540 x 455
Capacity : 6 Ltrs.
Power : 1.8 kw, 220V



Double Group Coffee Machine
Size(mm) : 750 x 540 x 455
Capacity : 10.5 Ltrs.
Power : 3 kw, 220V



Coffee Grinder
Size(mm) : 270 x 375 x 165
Capacity : 0.5 Kgs.
Power : 0.14 kw, 220V

Dish Washing Equipment



Hood Type Dish Washer Machine
Size(mm) : 670 x 785 x 1420(1860)
Capacity : 750 Plate/Hr.
Power : 8.16 kw, 440V
Crate Size(mm) : 500 x 500



Under Counter Dish Washer
Size(mm) : 595 x 655 x 830
Capacity : 560 Plate/Hr.
Power : 5.5 kw, 220V
Crate Size(mm) : 500 x 500



Under Counter Glass Washer
Size(mm) : 420 x 450 x 620
Capacity : 500 Glass/Hr.
Power : 3.3 kw, 220V
Crate Size(mm) : 350 x 350



Conveyor Type Dish Washer Machine
Size(mm) : 2050 x 800 x 1880
W/Dryer Capacity : 1650 Plate/Hr.
Power : 47 kw, 440V
Crate Size(mm) : 500 x 500
Also available without Dryer Model



Flushing Hose Reel
Available in 7.5 mtr / 15 mtr.



Pre-rinse Spray Unit
Available in Deck / Wall Mounted

FIRE SUPPRESSION SYSTEM

DEFENDER

The fusible links detect fire and trigger the system automatically

1



The manual activation unit trigger the system automatically

2



The activation mechanism shut off electric, gas and fans

3

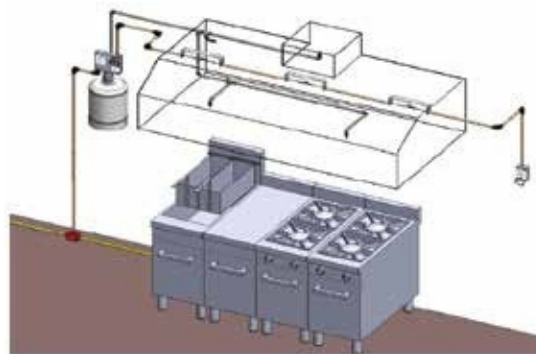

Cooking area and hood extinguishing system

The activation mechanism manually trigger the system automatically or

4



FE wet chemical extinguishant is in pressurized cylinder and release in to pipe after the triggering system.

5



FE wet chemical extinguishant release on fire through nazzles and extinguish the fire.

6



Step-1



Step-2



Step-3



Mob :- 7972011855, 70662 70008

Email :- Pioneerengineers511@gmail.com

Address :- Shop No. 2 Behind Jai Malhar Fish Mall,
chinchwadenagar, chinchwad 411033